

24011 series, 3/2 Direct solenoid actuated poppet valve

- Port size: 1/4" (ISO G or NPT), NAMUR Interface
- Main application: Single and double acting actuators
- TÜV-approval based on type examination DGRL 2014/68/EU and IEC 61508, multichannel up to SIL 3 (12 years)
- Add-on manual override or inductive limit switches on request
- Suited for outdoor use under critical environment conditions.
- Variable valve solenoid combination



Technical features

<p>Medium: Compressed air, filtered, non-lubricated and dry. Other gase and liquid fluids on request. (Viscosity for gaseous or liquid fluids up to 40 mm²/s)</p> <p>Operation: Direct solenoid operated poppet valve</p> <p>Operating pressure: 0 ... 10 bar (0 ... 145 psi)</p> <p>Orifice: 5 mm</p>	<p>Flow: Gaseous fluids: 340 l/min Liquid fluids: Cv 0,34</p> <p>Port size: G1/4, 1/4 NPT NAMUR Interface with integrated recirculation from the exhaust air to the acutator sping chamber</p> <p>Flow direction: Optional</p> <p>Mounting position: Any, but preferably with solenoid vertical</p>	<p>Ambient/Media temperature: NBR80 (Standard): -25 ... +80°C (-13 ... +176°F) FKM: -10...+120°C (+14 ... +248°F) Water +95°C (+203°F) NBR70 (Low temperature): -40... +60°C (-40 ... +140°F) Depending on solenoid system Air supply must be dry enough to avoid ice formation at temperatures below +2°C (35°F). For outdoor installations must be protected all connections against the penetration of moisture and a solenoid with IP66 protection must be used!</p>	<p>Materials: Body: Aluminium anodized (suitable for high humidity, sulphuric, sodium chloride or ammonia environments), brass 2.0401 (Ms 58) or stainless steel 1.4404 (316 L) Seal: FKM, NBR80, NBR70 Inner parts: stainless steel, brass</p> <p>Flow conversion: Cv US Gallon/min (water) = l/min (air) x 0,001 Kv m³/h (water) = l/min (air) x 0,000906</p>
---	---	---	--

Technical data Housing: Brass

Symbol	Port size	Operating pressure (bar)	Operating pressure (psi)	Material Seat seal	Manual override	Test certificate IEC 61508 2014/68/EU	Weight (kg)	Drawing No.	Solenoid group	Model *1)	
	G1/4	0 ... 10	0 .. 145	NBR80	Not possible	X	—	0,65	1	A + B	2401103
	G1/4	0 ... 10	0 .. 145	NBR80	Without detent	X	—	0,70	1	A + B	2401107
	G1/4	0 ... 10	0 .. 145	NBR80	With detent	—	—	0,70	1	A + B	2401119
	G1/4	0 ... 10	0 .. 145	NBR80	Not possible	X	X	0,65	1	A + B	2401149
	G1/4	0 ... 10	0 .. 145	FKM	Not possible	X	—	0,65	1	A + B	2401126
	G1/4	0 ... 10	0 .. 145	NBR70	Not possible	X	—	0,65	1	A + B	2401153
	G1/4	0 ... 10	0 .. 145	NBR70	Semi automatic	X	—	0,70	1	A + B	2401154
	1/4 NPT	0 ... 10	0 .. 145	NBR80	Not possible	X	X	0,65	1	A + B	2401138
	1/4 NPT	0 ... 10	0 .. 145	NBR80	Without detent	X	—	0,70	1	A + B	2401148
	1/4 NPT	0 ... 10	0 .. 145	NBR80	With detent	—	—	0,70	1	A + B	2401136
	1/4 NPT	0 ... 10	0 .. 145	NBR80	Semi automatic	X	—	0,70	1	A + B	2401140
	1/4 NPT	0 ... 10	0 .. 145	FKM	Not possible	X	—	0,65	1	A + B	2401131
	1/4 NPT	0 ... 10	0 .. 145	NBR70	Not possible	X	—	0,65	1	A + B	2401106
	1/4 NPT	0 ... 10	0 .. 145	NBR70	Without detent	X	—	0,70	1	A + B	1025226

*1) When ordering please indicate solenoid, voltage and current type (frequency).

Housing: Stainless steel

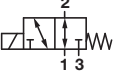
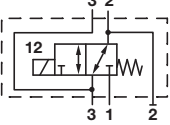
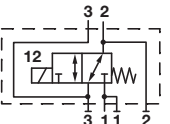
Symbol	Port size	Operating pressure (bar)	Material Seat seal	Manual override	Test certificate		Weight (kg)	Drawing No.	Solenoid group	Model *1)
					IEC 61508	2014/68/EU				
	G1/4	0 ... 10	NBR80	Not possible	X	X	0,65	2	A + B	2401186
	G1/4	0 ... 10	FKM	Not possible	—	—	0,70	2	A	2401127 *2)
	G1/4	0 ... 10	FKM	Without detent	—	—	0,70	2	A	2401170 *2)
	G1/4	0 ... 10	FKM	With detent	—	—	0,70	2	A	2401139 *2)
	G1/4	0 ... 10	NBR70	Not possible	—	X	0,65	2	A	2401155 *2)
	1/4 NPT	0 ... 10	NBR80	Not possible	X	X	0,65	2	A + B	2401112
	1/4 NPT	0 ... 10	FKM	Semi automatic	—	—	0,70	2	A + B	2401146
	1/4 NPT	0 ... 10	FKM	Not possible	X	—	0,65	2	A + B	1025227
	1/4 NPT	0 ... 10	FKM	Not possible	—	—	0,65	2	A	2401147 *2)
	1/4 NPT	0 ... 10	NBR70	Not possible	—	X	0,65	2	A	2401168 *2)
	G1/4 NAMUR	0 ... 10	NBR80	Without	X	—	1,00	2	A + B	2401196
	G1/4 NAMUR	0 ... 10	NBR70	Without	—	—	1,00	2	A	2401142
	G1/4 NAMUR	0 ... 10	NBR80	Without	X	X	1,00	3	A + B	1025212 *3)
	1/4 NPT NAMUR	0 ... 10	NBR80	Without	X	X	1,00	3	A + B	1025328 *3)

Housing: Aluminium anodized

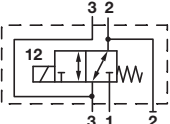
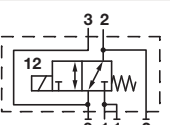
Symbol	Port size	Operating pressure (bar)	Material Seat seal	Manual override	Test certificate		Weight (kg)	Drawing No.	Solenoid group	Model *1)
					IEC 61508	2014/68/EU				
	G1/4 NAMUR	0 ... 10	NBR80	Without	X	X	0,55	3	A + B	2401191
	G1/4 NAMUR	0 ... 10	NBR80	Without	X	X	0,55	3	A + B	2401116 *4)
	G1/4 NAMUR	0 ... 10	NBR80	Without	—	—	0,70	5	A + B	1025333 *5)
	1/4 NPT NAMUR	0 ... 10	NBR80	Without	X	X	0,55	3	A + B	1025254
	G1/4 NAMUR	0 ... 10	NBR70	Without	X	—	0,55	3	A + B	2401133
	G1/4 NAMUR	0 ... 10	NBR80	Without	X	X	0,55	4	A + B	2401109 *3)

*1) When ordering please indicate solenoid, voltage and current type (frequency).

*2) Complete stainless steel version

*3) Port P in flange according to VDI/VDE 3845 for attachment of positioners or to interlinking plate (see data sheet N/en 5.8.300)

*4) Free of non-ferrous metals

*5) Proximity switch

Solenoids group A, standard voltages

Image	Power consumption		Rated current		Protection class IP/NEMA	Ex-Protection (ATEX-Category)	Temperature Ambient/Media (°C)	Electrical connection	Drawing	Circuit diagram	Model
	24 V d.c. (W)	230 V a.c. (VA)	24 V d.c. (mA)	230 V a.c. (mA)					No.	No.	
	16,9	—	703	—	IP65 (with connector)	—	-25 ... +60 Media: +80 max	Connector DIN EN 175301-803, Form A *6)	3	1	0800
	—	17,3	—	75	IP65 (with connector)	—	-25 ... +60 Media: +80 max	Connector DIN EN 175301-803, Form A *6)	4	6	3803
	8,9	—	369	—	IP65	—	-30...+90 Media: +110	Terminals, cable gland Pg 13,5	9	2	4120
	—	10	—	43	IP65	—	-30...+90 Media: +110	Terminals, cable gland Pg 13,5	9	6	4121
	8,9	—	369	—	IP67	—	-30...+90 Media: +110	3 m cable, encapsulated in EP resin	9	2	4122
	—	10	—	43	IP67	—	-30...+90 Media: +110	3 m cable, encapsulated in EP resin	9	6	4123
	8,9	—	369	—	IP66 (with cable gland)	II 2G Ex eb mb IIC T4/ T5 Gb	T4: -40 ... +65 T5: -40 ... +55 -40 ... +65	M20 x 1,5 *6)	6	4	4270
	—	10,0	—	43	IP66 (with cable gland)	II 2D Ex tb IIIC T130°C Db	T4: -40 ... +65 T5: -40 ... +55 -40 ... +65	M20 x 1,5 *6)	6	7	4271
	8,9	—	369	—	IP66 (with cable gland)	II 2G Ex db mb IIC T4/ T6 Gb	T4: -40 ... +70 T6: -40 ... +40	1/2 NPT *6)	7	20	4670
	—	10,0	—	43	IP66 (with cable gland)	II 2G Ex eb mb IIC T4/ T6 Gb	T4: -40 ... +70 T6: -40 ... +40	1/2 NPT *6)	7	21	4671
	8,9	—	369	—	IP66 (with cable gland)	II 2G Ex db mb IIC T4/ T6 Gb	T4: -40 ... +70 T6: -40 ... +40	M20 x 1,5 *6)	7	20	4672
	—	10,0	—	43	IP66 (with cable gland)	II 2G Ex eb mb IIC T4/ T6 Gb	T4: -40 ... +70 T6: -40 ... +40	M20 x 1,5 *6)	7	21	4673
	8,9	—	369	—	IP66 (with cable gland)	II 2G Ex db mb IIC T4 Gb	T4: -40 ... +50	M20 x 1,5 *6)	10	4	4872
	—	10	—	43	IP66 (with cable gland)	II 2G Ex eb mb IIC T4 Gb	T4: -40 ... +50	M20 x 1,5 *6)	10	7	4873
	13,6	—	567	—	4x	CL I, Div. 1, Gr. A - D CL II/III, Div. 1, Gr. E - G T3C (160°C)	-20 ... +60	Flying leads length 460 mm	8	1	3826
	—	15,7	—	68	4x	CL I, Div. 1, Gr. A - D CL II/III, Div. 1, Gr. E - G T3C (160°C)	-20 ... +60	Flying leads length 460 mm	8	5	3827

Standard voltages (±10%) 24 V d.c., 230 V a.c., other voltages on request. Design according to VDE 0580, EN 50014/50028. 100% duty cycle.

*6) Connector/cable gland is not scope of delivery, see table »Accessories

Attention: The protection class for coil series 46xx and 48xx is determined by the choice of cable gland. Example: if an ATEX-certified cable gland is used that has Ex d type of protection, the solenoid will have the protection class Ex d mb; if a cable gland with Ex e type of protection is used, the solenoid will have protection class Ex e mb.

Approvals

Model	Approvals ATEX	IECEX	FM	Datasheet
382x	—	—	CSA-LR 57643-6	N/en 71.575
42xx	KEMA 98 ATEX 4452 X	IECEX KEM 09.0068X	—	N/en 71.580

Approvals

Model	Approvals ATEX	IECEX	Datasheet
46xx	PTB 02 ATEX 2085 X	IECEX PTB 11.0094X	N/en 71.585
48xx	EPS 18 ATEX 1 019	IECEX EPS 18.0013	N/en 71.590

Solenoids group B, standard voltages

	Power consumption		Rated current		Protection class IP/NEMA	Ex-Protection (ATEX-Category)	Temperature Ambient/Media (°C)	Electrical connection	Drawing	Circuit diagram	Model
	24 V d.c. (W)	230 V a.c. (VA)	24 V d.c. (mA)	230 V a.c. (mA)					No.	No.	
	6,8	—	284	—	IP65 (with connector)	—	-25 ... +60	Connector DIN EN 175301-803, form A *6)	2	1	0827
	—	10,6	—	46	IP65 (with connector)	—	-25 ... +60	Connector DIN EN 175301-803, form A *6)	3	6	3805
	3,9	—	162	—	IP65	—	-30...+100 Media: +110	Terminals, cable gland Pg 13,5	9	2	4140
	—	5,3	—	23	IP65	—	-30...+100 Media: +110	Terminals, cable gland Pg 13,5	9	6	4141
	3,9	—	162	—	IP67	—	-30...+100 Media: +110	3 m cable, encapsulated in EP resin	9	2	4142
	—	5,3	—	23	IP67	—	-30...+100 Media: +110	3 m cable, encapsulated in EP resin	9	6	4143
	3,9	—	162	—	IP66 (with cable gland)	II 2G Ex eb mb IIC T4/ T6 Gb	T4: -40 ...+80 T6: -40 ... +55 -40 ...+80	M20 x 1,5 *6)	6	4	4260
	—	5,3	—	23	IP66 (with cable gland)	II 2D Ex tb IIIC T130°C Db II 2G Ex eb mb IIC T4/ T6 Gb	T4: -40 ...+80 T6: -40 ... +55 -40 ...+80	M20 x 1,5 *6)	6	7	4261
	3,9	—	162	—	IP66 (with cable gland)	II 2G Ex db mb IIC T4/ T6 Gb II 2G Ex eb mb IIC T4/ T6 Gb II 2D Ex tb IIIC T130°C Db	T4: -40 ...+80 T6: -40 ... +55 -40 ...+80	1/2 NPT *6)	7	20	4660
	—	5,3	—	23	IP66 (with cable gland)	II 2G Ex db mb IIC T4/ T6 Gb II 2G Ex eb mb IIC T4/ T6 Gb II 2D Ex tb IIIC T130°C Db	T4: -40 ...+80 T6: -40 ... +55 -40 ...+80	1/2 NPT *6)	7	21	4661
	3,9	—	162	—	IP66 (with cable gland)	II 2G Ex db mb IIC T4/ T6 Gb II 2G Ex eb mb IIC T4/ T6 Gb II 2D Ex tb IIIC T130°C Db	T4: -40 ...+80 T6: -40 ... +55 -40 ...+80	M20 x 1,5 *6)	7	20	4662
	—	5,3	—	23	IP66 (with cable gland)	II 2G Ex db mb IIC T4/ T6 Gb II 2G Ex eb mb IIC T4/ T6 Gb II 2D Ex tb IIIC T130°C Db	T4: -40 ...+80 T6: -40 ... +55 -40 ...+80	M20 x 1,5 *6)	7	21	4663
	8,9	—	369	—	4x	Cl. I, Div. 1, Gr. A - D Cl. II/III, Div. 1, Gr. E - G T3C (160°C)	-20 ... +60	Flying leads length 460 mm	8	1	3824
	—	9,5	—	41	4x	Cl. I, Div. 1, Gr. A - D Cl. II/III, Div. 1, Gr. E - G T3C (160°C)	-20 ... +60	Flying leads length 460 mm	8	5	3825

Standard voltages (±10%) 24 V d.c., 230 V a.c., other voltages on request. Design according to VDE 0580, EN 50014/50028. 100% duty cycle.

*6) Connector/cable gland is not scope of delivery, see table »Accessories

Attention: The protection class for coil series 46xx and 48xx is determined by the choice of cable gland.

Example: if an ATEX-certified cable gland is used that has Ex d type of protection, the solenoid will have the protection class Ex d mb; if a cable gland with Ex e type of protection is used, the solenoid will have protection class Ex e mb.

Approvals

Model	Approvals			Datasheet
	ATEX	IECEX	FM	
372x, 382x	—	—	CSA-LR 57643-6	N/en 71.575
42xx	KEMA 98 ATEX 4452 X	IECEX KEM 09.0068X	—	N/en 71.580
46xx	PTB 02 ATEX 2085 X	IECEX PTB 11.0094X	—	N/en 71.585

Partnumbers for international approval

Land/Approval	Coil/Code	321x	372x	42xx	46xx
Europa/ATEX	Standard	x	-	x	x
International/IECEX	Standard	x	-	x	x
China/NEPSI	-01	-	-	x	x
Brasilien/INMETRO	-02	-	-	x	x
Korea/KOSHA (only gas approval)	-03	-	-	x	x
Russland, Kasachstan & Weißrussland/TR-CU 012	-04	-	-	x	x
Indien/CCOE	Standard	-	-	x	x
Taiwan/ITRI	Standard	-	-	x	x
USA/FM	Standard	-	x	-	-
Kanada/CSA	Standard	-	x	-	-

Example: 000000422002400-04
(Coil: 4220; Voltage: 24V DC; Approval: TR-CU 012)

Accessories

Electrical connection

Cable gland
Protection class Ex e, Ex d (ATEX),
Nickel plated brass/
Stainless steel



Page 10

For sole-noid	Thread	Cable Ø (mm)	Material	Protection class (ATEX)	Ambient temperatur limitation *7)	Model
42xx	M20 x 1,5	7,0 ... 12,0	Plastic	II 2G Ex e / II 2D Ex t	See table	0589735
42xx	M20 x 1,5	10,0 ... 14,0	Plastic	II 2G Ex e / II 2D Ex t	See table	0589736
42xx	M20 x 1,5	6,0 ... 12,0	Plastic	II 2G Ex e / II 2D Ex t	See table	0589737
42xx	M20 x 1,5	5,0 ... 10,0	Plastic	II 2G Ex e / II 2D Ex t	See table	0589739
46xx	M20 x 1,5	5,0 ... 14,0	Nickel plated brass	II 2G Ex e / II 2D Ex t	-	0589654
46xx	M20 x 1,5	10,0 ... 14,0	Nickel plated brass	II 2G Ex d / II 2D Ex t	-	0588851
46xx	1/2 NPT	7,5 ... 11,9	Nickel plated brass	II 2G Ex d / II 2D Ex t	-	0588925
46xx, 48xx	M20 x 1,5	9,0 ... 13,0	Stainless steel 1.4571	II 2G Ex e / II 2D Ex t	-	0589385
46xx, 48xx	M20 x 1,5	7,0 ... 12,0	Stainless steel 1.4404	II 2G Ex d / II 2D Ex t	-	0589395
46xx, 48xx	M20 x 1,5	10,0 ... 14,0	Stainless steel 1.4404	II 2G Ex d / II 2D Ex t	-	0589387

*7) The limitation of the temperature range to the mentioned range is due to the self-heating of the solenoid.

For sole-noid	Ambient temperatur limitation solenoid 42xx		
	0589735 & 0589736 *8)	0589737	0589739 *8)
421x/426x	T4 & Dust Ex: -35°C ... + 80°C	T4 & Dust Ex: -40°C...+ 65°C	T4 & Dust Ex: -40...+78°C
	T6: -35°C ... + 55°C	T6: -40°C...+ 55°C	T6: -40...+55°C
422x/427x	T4 & Dust Ex: -35°C +65°C	T4 & Dust Ex: -40°C...+ 62°C	T4 & Dust Ex: -40...+65°C
	T5: -35°C + 55°C	T5: -40°C + 55°C	T5: -40...+55°C

*8) Tested for the lower level of mechanical risk (4 joule), an additional protection against impacts might be needed.

Connector
DIN EN 175301-803



0570275 (form A)

Connector for proximity switch 4-pin, 90° Page 13 0523058 (2 m cable,4-core) 0523053 (5 m cable,4-core)	4-pin, 90° Page 13 0523056 (without cable)	4-pin, straight Page 13 0523057 (2 m cable, 4-core) 0523052 (5 m cable, 4-core)	4-pin, straight Page 13 0523055 (without cable)	Silencer *9) Page 11 C/S2 (1/4 NPT) M/S2 (G1/4)	Exhaust guard *10) Page 11 0613422 (G1/4, 1/4 NPT)
--	--	---	--	---	---

Filter Page 11 0681173 (G1/4, 1/4 NPT)	Add-on manual override *11) Without detent Page 8 0600205	with detent Page 8 0601765
---	---	---

Manual Override

The manual override is meant to be used for system testing. Upon de-energisation of the coil the valve returns to rest position by mechanical spring force (for testing only prior to commissioning).

Semi automatic/Manual reset

Function: The valve does not switch after energisation of the coil. It will only operate if the reset button is being pushed. The valve will then, by means of the coil voltage, be held in its switching position even if the reset button is being released. It will return to rest position when the coil is being de-energised. Allowable voltage tolerance: +/- 10%.

- *9) For indoors use
 - *10) For outdoors use, opening pressure ~ 0,2 bar
 - *11) Add on for NAMUR valves always possible, Inline on request
- Using the manual override with detent cancels the SIL-Approval!

NAMUR accessories

Throttle control plate *12) Page 12 4040239	Flange plate Page 11 & 12 0612790 (NAMUR single connection plate) 0612791 (NAMUR-rip use in combination with 0612790)	Yoke Page 12 0540593	Distance plate for pressure switches Page 12 0540109	Mounting plate Page 11 0613453 (90°) 0612631 (180°) 0613556 (270°)	Quick exhaust module *13) Page 12 4050218
--	---	---------------------------------------	---	---	--

- *12) The throttle control plate 4040239 has a minimum flow rate for safety reason.
- *13) Technical details see catalogue page en 5.4.820.

Drawings
Valves

Dimensions in mm
Projection/First angle



1

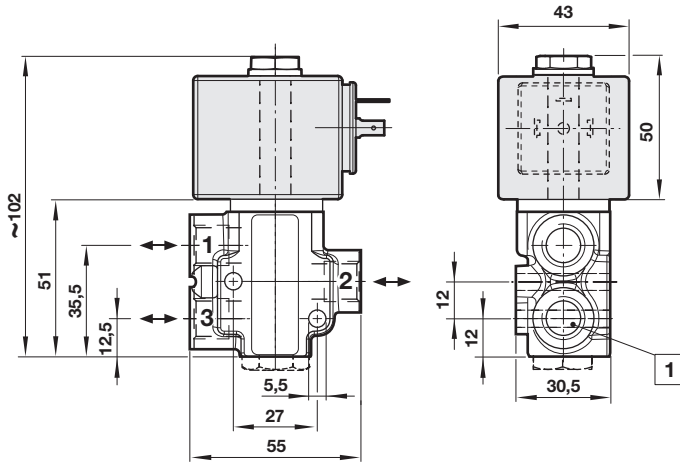

2

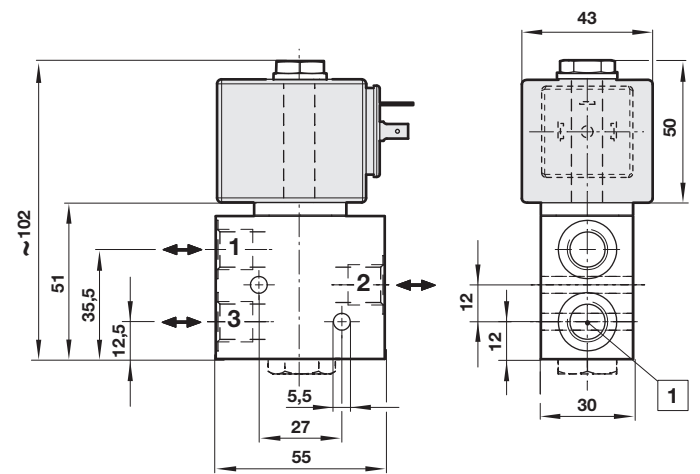

3

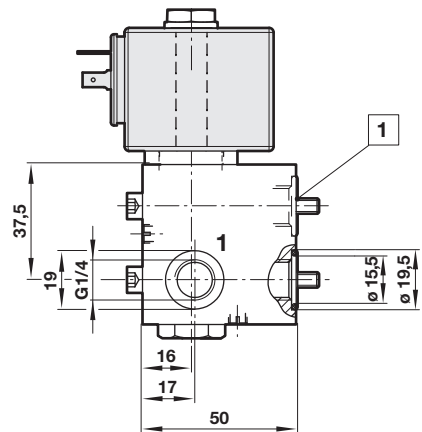
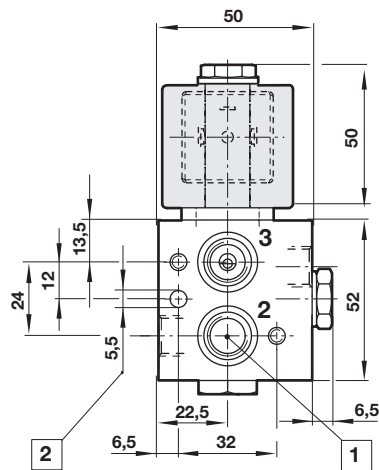
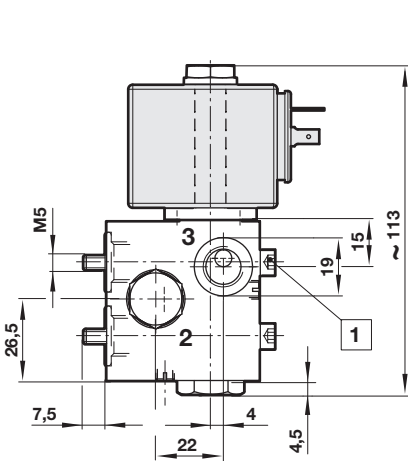

- 2 Port size G1/4 or 1/4 NPT
- 3 3 mm deep
- 4 Retrofit option for manual override

4

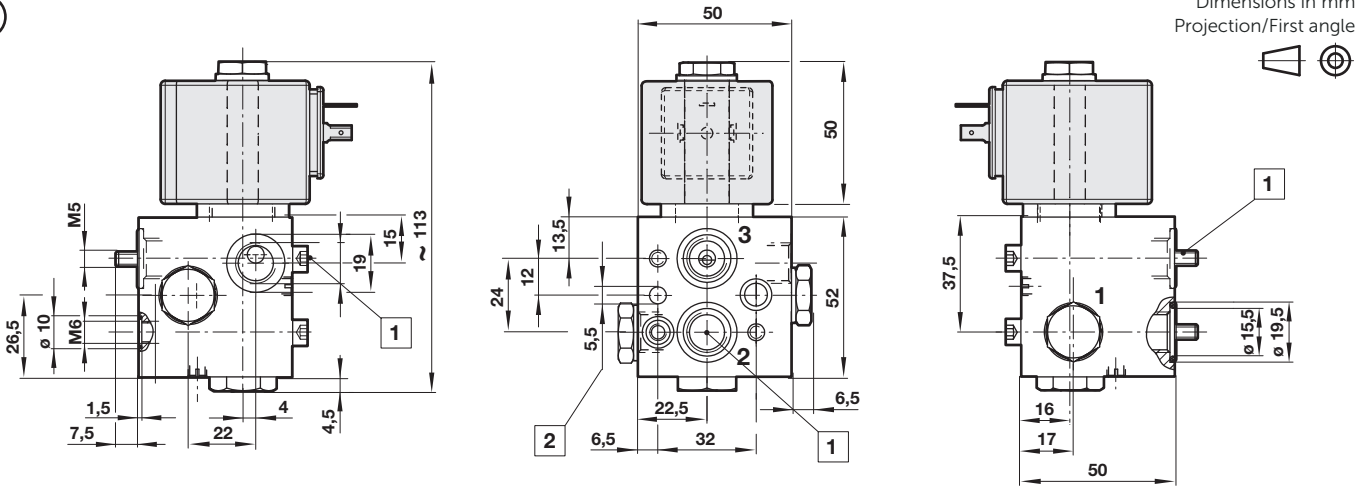

Dimensions in mm
Projection/First angle



- 1 Port size G1/4 or 1/4 NPT
- 2 3 mm deep
- 3 Retrofit option for manual override

Add-on manual override

Without detent
Model: 0600205

With detent
Model: 0601765

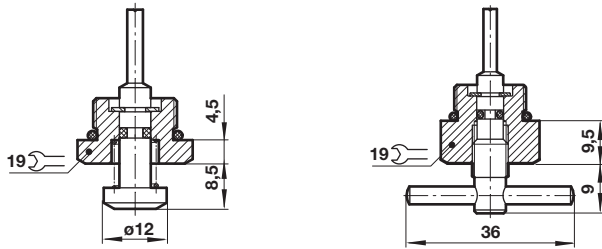

Please note: add-on manual override for NAMUR valves provided only for commissioning and tests

5

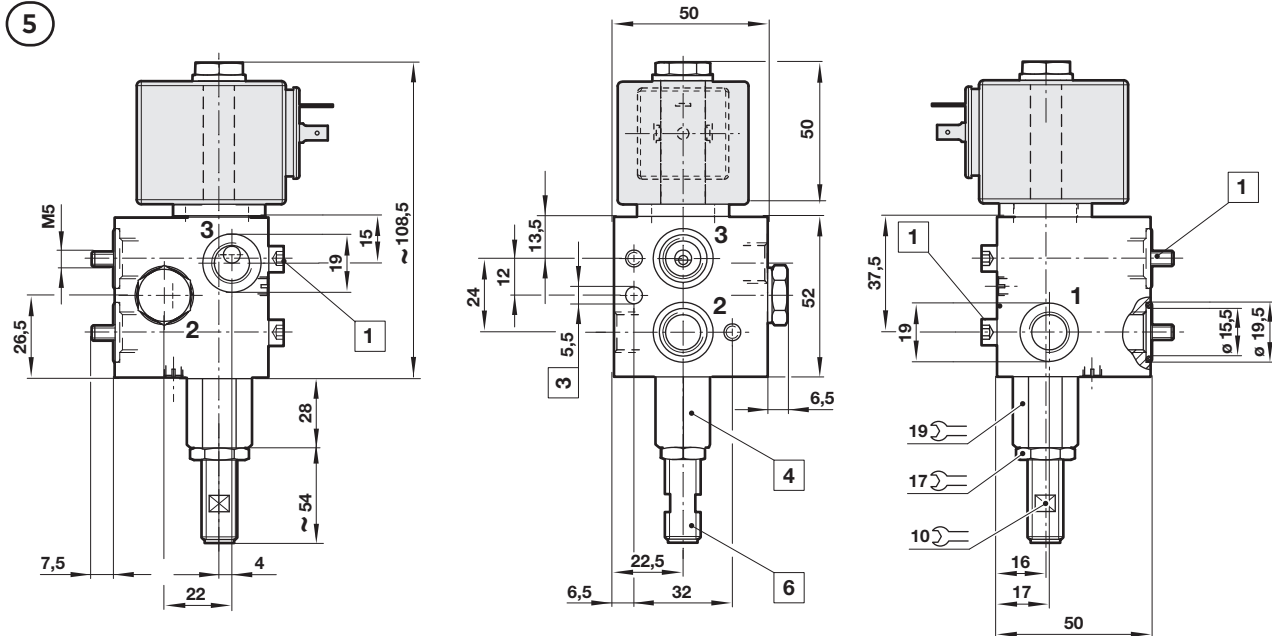

- 3 3 mm deep
- 4 Proximity switch
- 6 Thread M12 x 1

Proximity switch Technical features

Supply voltage (U_b):
7,7 ... 9 V d.c.
Ripple:
15%
Frequency of operating cycles:
1000 Hz

Protection class:
IP68
Pressure-resistant:
500 bar (7251 psi)
Ambient temperature:
-25 ... +70°C (-13 ... +158°F)

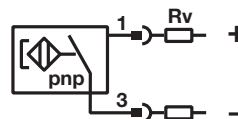

Solenoids

Dimensions in mm
Projection/First angle



3 Weight: 0,27 kg

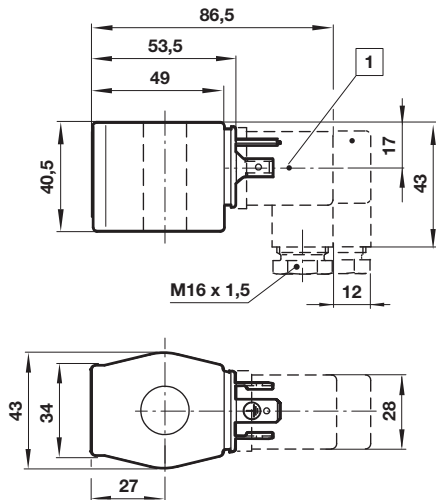

4 Weight: 0,32 kg

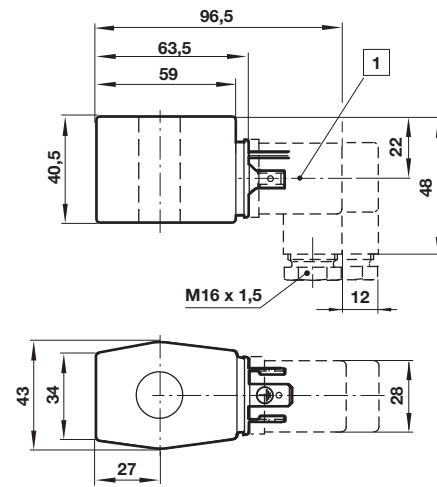

6 Weight: 0,6 kg

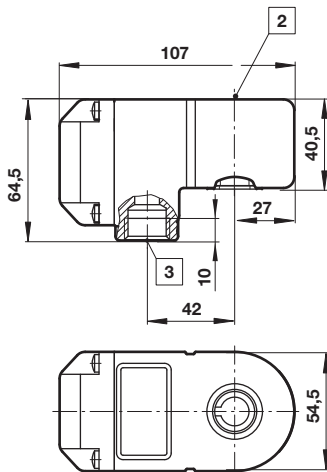

7 Weight: 0,7 kg

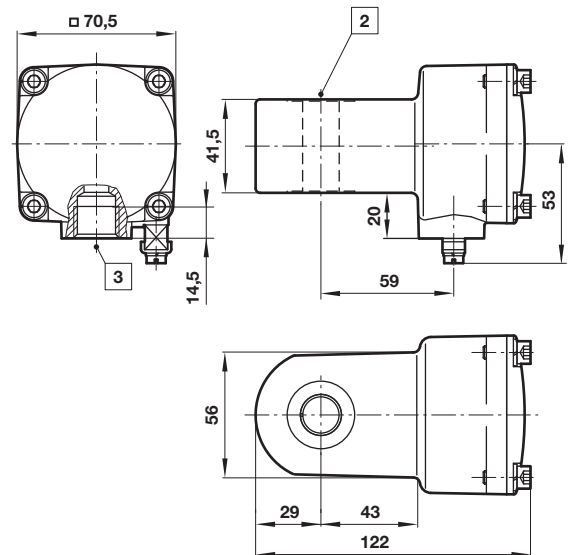

8 Weight: 0,8 kg

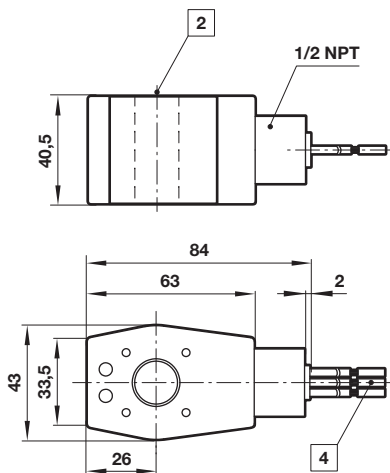

9 Weight: 0,7 kg

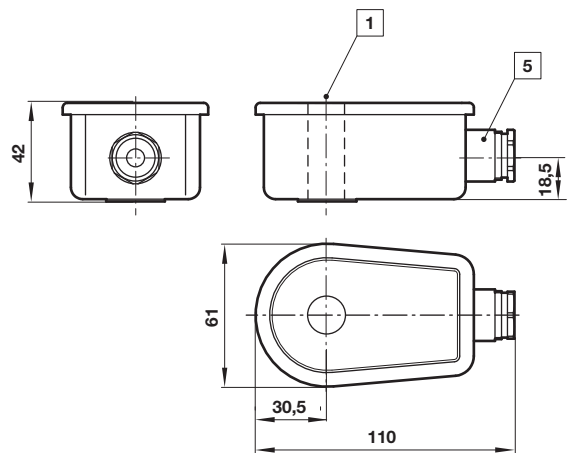

- 1 Connector can be indexed by 4x90°
- 2 Ø 16 or 13 (with spacer tube)
- 3 M20 x 1,5 or 1/2 NPT
- 4 Flying leads AWG 18 (460 mm long)
- 5 With cable gland, Pg 13,5

10 Weight: 1,2 kg

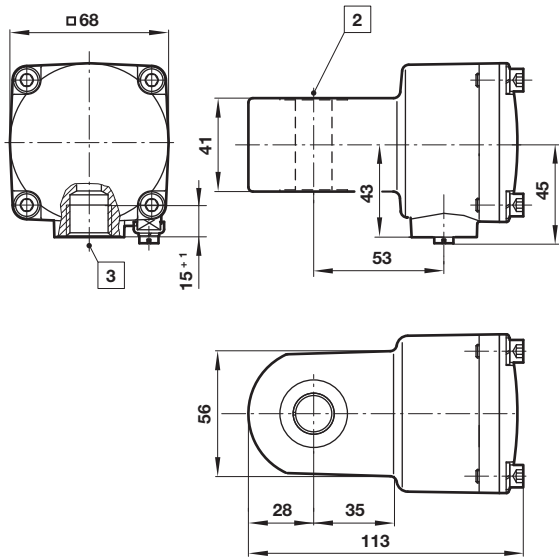

2 Ø 16
3 M20 x 1,5

Circuit diagrams

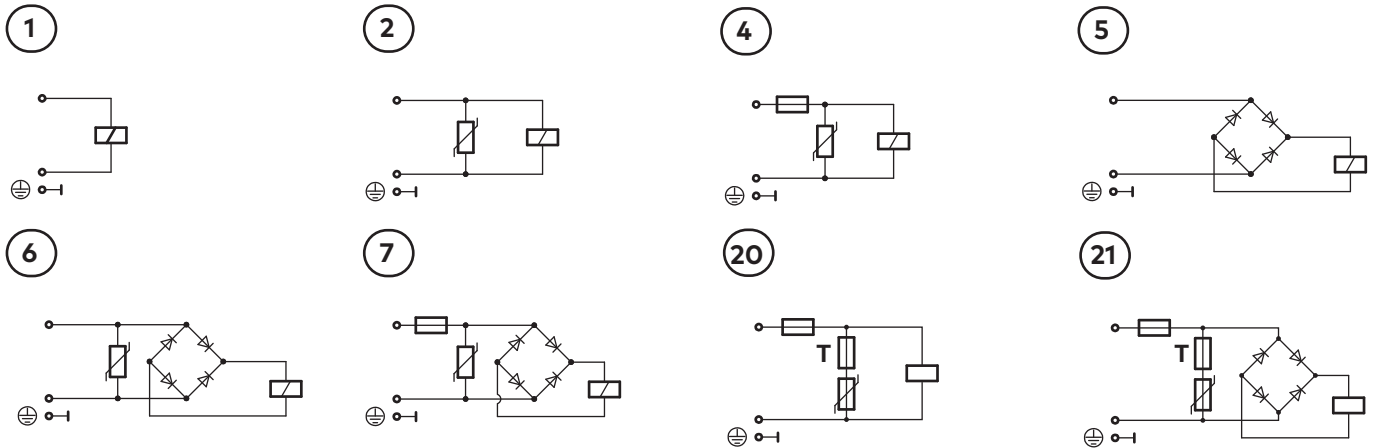

Cable gland

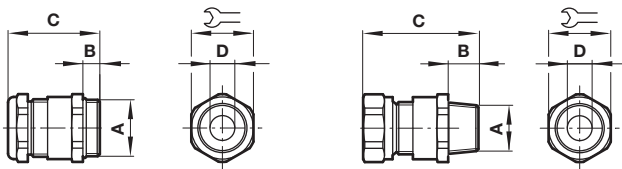

0588925 only

A	B	C	øD		Model
M20 x 1,5	10	40	7,0 ... 12,0	24	0589735
M20 x 1,5	10	43	10,0 ... 14,0	27	0589736
M20 x 1,5	10	40	6,0 ... 12,0	24	0589737
M20 x 1,5	10	39,5	5,0 ... 10,0	24	0589739
M20 x 1,5	6,5	35,5	5,0 ... 14,0	24	0589654
M20 x 1,5	12	37	9,0 ... 14,0	30	0588851
1/2 NPT	15	58	7,5 ... 11,9	24	0588925
M20 x 1,5	6,5	27,5	9,0 ... 13,0	22	0589385
M20 x 1,5	16	40	7,0 ... 12,0	24	0589395
M20 x 1,5	16	41	10,0 ... 14,0	24	0589387

NAMUR hole pattern (actuator side)

NAMUR quick exhaust module for a better kv-value by exhaust see data sheet 5.4.820

NAMUR interlinking plates in redundancy design for »safety exhausting« and »safety ventilating« see data sheet 5.4.830

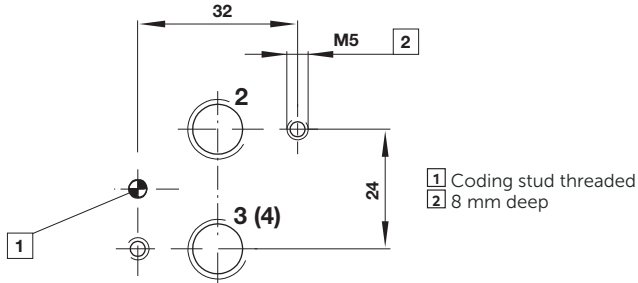

Accessories

Silencer

Model: M/S2, C/S2

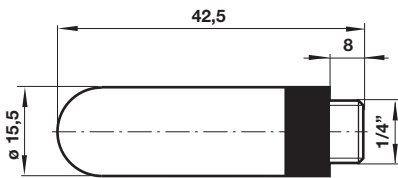

Exhaust guard

Model: 0613422

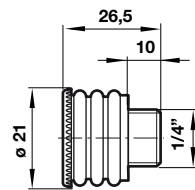

Dimensions in mm
Projection/First angle



Single connection plate

Model:
0612790

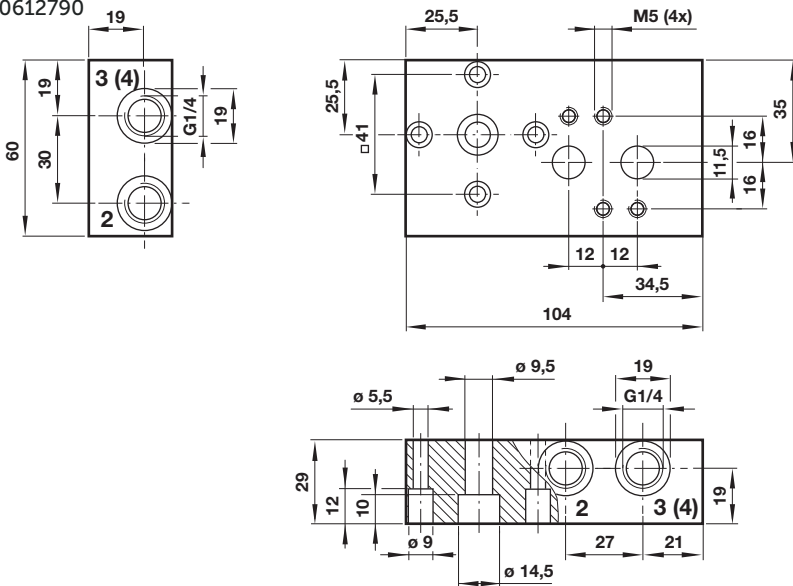

Mounting plate

Model: 0613453
(90°)

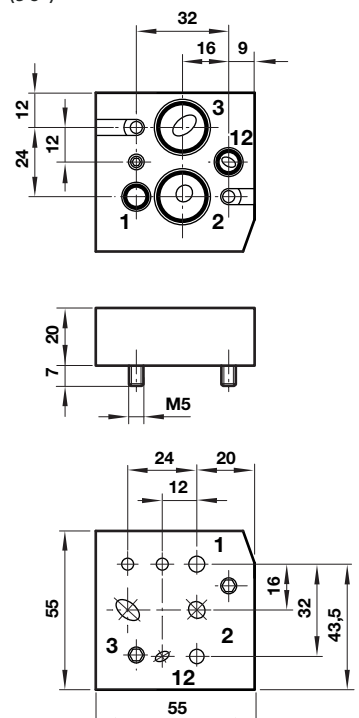

NAMUR slot
Model: 0612791

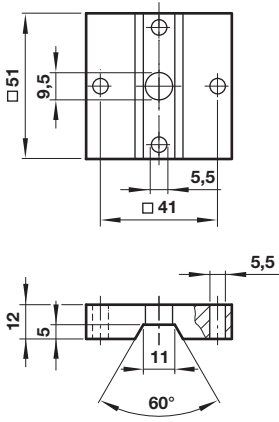

Yoke
Model:
0540593

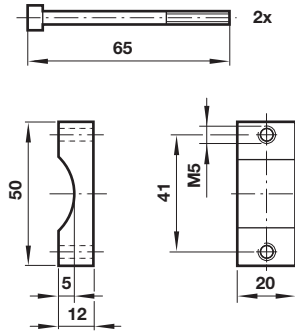

Throttle control plate
Model:
4040239

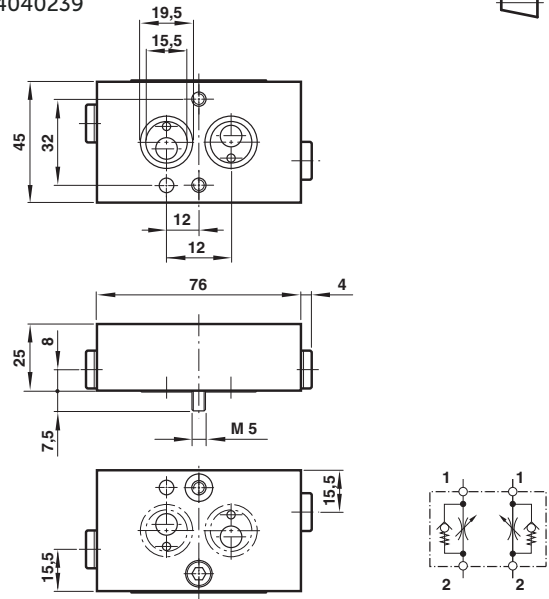

Dimensions in mm
Projection/First angle



Quick exhaust module

Typ: 4050218

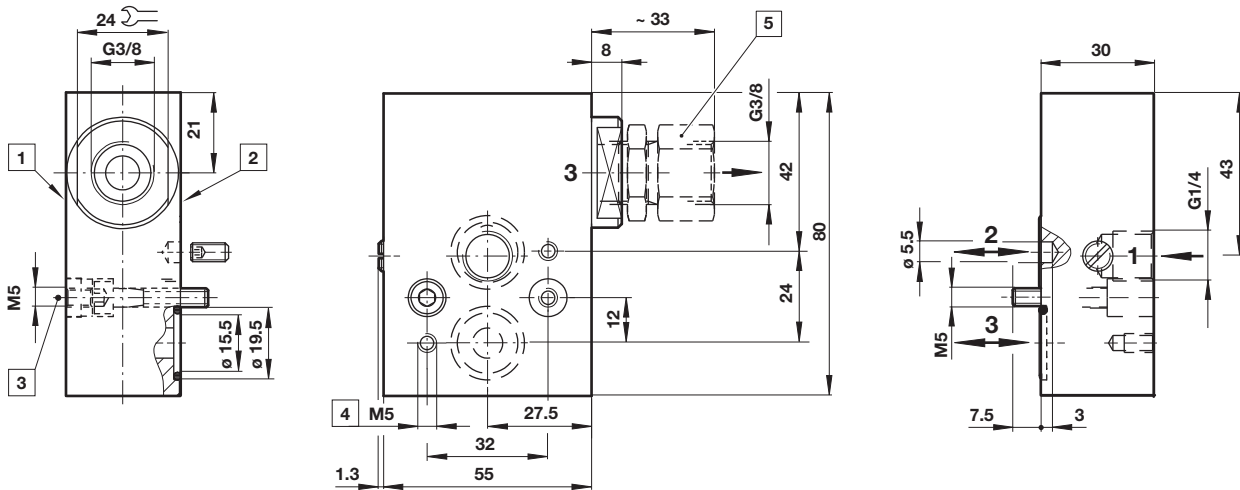

- 1 Flanged surface NAMUR or externally mounted valve
- 2 Flanged surface NAMUR actuator
- 3 Push-in threaded piece after plate mounting (to secure correct position)
- 4 8 mm deep
- 5 Flow regulator retrofittable

Connector 90°, 4 pin, with PUR cable

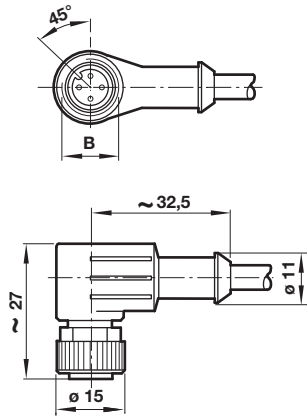

B	C	øD	øD1	F	Wire x dim.	Cable length (m)	Weight (g)	Model
M12 x 1	32,5	15	11	27	4 x 0,34 mm ²	2	90	0523058
M12 x 1	32,5	15	11	27	4 x 0,34 mm ²	5	180	0523053

90°, 4 pin, without cable

Dimensions in mm
Projection/First angle

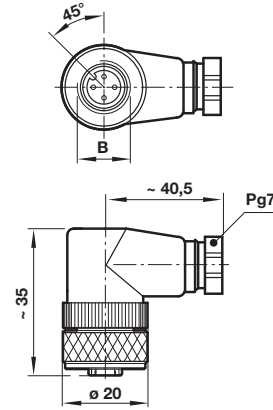

B	C	øD	E	F	Weight (g)	Model
M12 x 1	40,5	20	Pg 7	35	30	0523056

Straight, 4 pin, with PUR cable

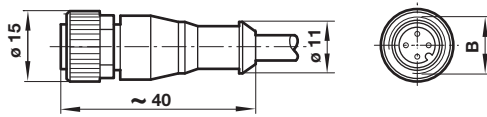

B	C	øD	øD1	Wire x dim.	Cable length (m)	Weight (g)	Model
M12 x 1	40	15	11	4 x 0,34 mm ²	2	80	0523057
M12 x 1	40	15	11	4 x 0,34 mm ²	5	200	0523052

Straight, 4 pin, without cable

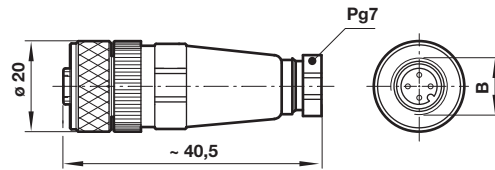

B	C	øD	E	Weight (g)	Model
M12 x 1	40,5	20	Pg 7	26	0523055

Warning

These products are intended for use in industrial compressed air and fluid systems only. Do not use these products where pressures and temperatures can exceed those listed under »**Technical features/data**«. Before using these products with fluids other than those specified, for non-industrial applications, life-support systems, or other applications not within published specifications, consult Norgren GmbH.

Through misuse, age, or malfunction, components used in fluid power systems can fail in various modes.

The system designer is warned to consider the failure modes of all component parts used in fluid power systems and to provide adequate safeguards to prevent personal injury or damage to equipment in the event of such failure. System designers must provide a warning to end users in the system instructional manual if protection against a failure mode cannot be adequately provided.

System designers and end users are cautioned to review specific warnings found in instruction sheets packed and shipped with these products.

Functional safety (SIL):

Suitable for certain applications can only be evaluated through examination of each safety-related overall system with regard to the requirements of IEC 61508/61511.