

## 25003, 5/2 Direct actuated poppet valves

- 1/4" (G or NPT) to 2014/68/EU  
Inline & NAMUR
- Main application: Double acting actuators
- Ports 2 and 4 can be controlled by throttle check valves
- Approval according



### Technical features

#### Medium:

Neutral or aggressive, gaseous fluids which do not damage the product or affect the function (e.g. compressed air, nitrogen). Based on ISO 8573-1-2010 classification 1-2-3.

#### Operation:

Direct solenoid operated poppet valves

#### Operating pressure:

0 ... 8 bar (0 ... 116 psi) or  
0 ... 10 bar (0 ... 145 psi)

#### Flow:

530 l/min  
Kv: 0,48

#### Port size:

G1/4, G1/4 NAMUR, 1/4 NPT

#### Flow direction:

Fixed

#### Mounting position:

Any, but preferably with solenoid vertical

#### Switching cycles:

100/min

#### Fluid temperature:

NBR: -20 ... +80°C (-4 ... +176°F)  
FKM: -10 ... +120°C (+14 ... +248°F)  
Water +90°C (+194°F) max.  
Depending on solenoid system and sealing

#### Ambient temperature:

-20 ... +80°C (-4 ... +176°F)  
Depending on solenoid system  
Air supply must be dry enough to avoid ice formation at temperatures below +2°C (+35°F).

#### Materials:

Valve housing: brass 2.0401 (Ms 58), stainless steel 1.4404 (316 L), hard-anodised aluminium 3.0615 (NAMUR version)  
Seal: NBR, FKM  
Inner parts: brass, stainless steel

#### Flow conversion:



Cv US Gallon/min (water) =  
l/min (air) x 0,001  
Kv m<sup>3</sup>/h (water) =  
l/min (air) x 0,000906

### Technical data

Symbol	Port size	Operating pressure (bar)	Material Seat seal	Housing	Manual override	Test certificate 2014/68/EU	Weight (kg)	Dimension No.	Model *1)
	G1/4 NAMUR	0 ... 8	NBR	Aluminium	Without	X	0,65	3	2500335
	G1/4	0 ... 8	NBR	Brass	Without	X	1,15	1	2500300
	1/4 NPT	0 ... 10	NBR	Brass	Without		1,15	1	2500306
	G1/4	0 ... 10	NBR	Brass	With		1,15	2	2500311
	G1/4	0 ... 10	NBR	Brass	With		1,15	2	2500316
	G1/4	0 ... 10	FKM	Stainless steel	Without		1,35	1	2500302
	1/4 NPT	0 ... 10	FKM	Stainless steel	Without		1,35	1	2500308

\*1) Please add solenoid, voltage and power supply data (frequency) when ordering

## Solenoids operators

	Power consumption		Rated current		Protection class IP/NEMA	Ex-Protection (ATEX-Category)	Temperature Ambient/Media (°C)	Electrical connection	Drawing	Circuit diagram	Model
	24 V d.c. (W)	230 V a.c. (VA)	24 V d.c. (m A)	230 V a.c. (m A)					No.	No.	
	16,9	—	703	—	IP65 (with connector)	—	-25 ... +60 Media: +80 max	Connector DIN EN 175301-803, Form A *2)	3	1	0800
	—	17,3	—	75	IP65 (with connector)	—	-25 ... +60 Media: +80 max	Connector DIN EN 175301-803, Form A *2)	4	6	3803
	8,9	—	369	—	IP66 (with cable gland)	II 2G Ex eb mb IIC T4/ T5 Gb	T4: -40 ... +65 T5: -40 ... +55 -40 ... +65	M20 x 1,5 *2)	6	4	4270
	—	10,0	—	43	IP66 (with cable gland)	II 2D Ex tb IIIC T130°C Db	T4: -40 ... +65 T5: -40 ... +55 -40 ... +65	M20 x 1,5 *2)	6	7	4271
	8,9	—	369	—	IP66 (with cable gland)	II 2G Ex tb IIIC T130°C Db II 2G Ex db mb IIC T4/T6 Gb II 2G Ex eb mb IIC T4/T6 Gb II 2D Ex tb IIIC T130°C Db	T4: -40 ... +70 T6: -40 ... +40 -40 ... +70	1/2 NPT *2)	7	20	4670
	—	10,0	—	43	IP66 (with cable gland)	II 2G Ex db mb IIC T4/T6 Gb II 2G Ex eb mb IIC T4/T6 Gb II 2D Ex tb IIIC T130°C Db	T4: -40 ... +70 T6: -40 ... +40 -40 ... +70	1/2 NPT *2)	7	21	4671
	8,9	—	369	—	IP66 (with cable gland)	II 2G Ex db mb IIC T4/T6 Gb II 2G Ex eb mb IIC T4/T6 Gb II 2D Ex tb IIIC T130°C Db	T4: -40 ... +70 T6: -40 ... +40 -40 ... +70	M20 x 1,5 *2)	7	20	4672
	—	10,0	—	43	IP66 (with cable gland)	II 2G Ex db mb IIC T4/T6 Gb II 2G Ex eb mb IIC T4/T6 Gb II 2D Ex tb IIIC T130°C Db	T4: -40 ... +70 T6: -40 ... +40 -40 ... +70	M20 x 1,5 *2)	7	21	4673

Standard voltages ( $\pm 10\%$ ) 24 V d.c., 230 V a.c., other voltages on request. Design according to VDE 0580, EN 50014/50028. 100% duty cycle.

\*2) Connector/cable gland is not scope of delivery, see table »Accessories

Attention: The protection class for coil series 46xx is determined by the choice of cable gland. Example: if an ATEX-certified cable gland is used that has Ex d type of protection, the solenoid will have the protection class Ex d mb; if a cable gland with Ex e type of protection is used, the solenoid will have protection class Ex e mb.

## Approvals

Model	Approvals		Datasheet
	ATEX	IECEX	
42xx	KEMA 98 ATEX 4452 X	IECEX KEM 090068X	7.1580
46xx	PTB 02 ATEX 2085 X	IECEX PTB 11.0094X	7.1585

## Partnumbers for international approval

Land/Approval	Coil/Code	42xx	46xx
Europa/ATEX	Standard	x	x
International/IECEX	Standard	x	x
China/NEPSI	-01	x	x
Brasilien/INMETRO	-02	x	x
Korea/KOSHA	-03	x	x
Russland, Kasachstan & Weißrussland/TR-CU 012	-04	x	x
Indien/CCOE	Standard	x	x
Taiwan/ITRI	Standard	x	x
USA/FM	Standard	—	—
Kanada/CSA	Standard	—	—

Example: 0000000427002400-04

(Coil: 4270; Voltage: 24V DC; Approval: TR-CU 012)

## Accessories

### Electrical connection

Cable gland  
Protection class Ex e, Ex d (ATEX),  
Nickel plated brass/  
Stainless steel





Page 7

For solenoid	Thread	Cable Ø (mm)	Material	Protection class (ATEX)	Ambient temperatur limitation *3)	Model
42xx	M20 x 1,5	7,0 ... 12,0	Plastic	II 2G Ex e / II 2D Ex t	See table	0589735
42xx	M20 x 1,5	10,0 ... 14,0	Plastic	II 2G Ex e / II 2D Ex t	See table	0589736
42xx	M20 x 1,5	6,0 ... 12,0	Plastic	II 2G Ex e / II 2D Ex t	See table	0589737
42xx	M20 x 1,5	5,0 ... 10,0	Plastic	II 2G Ex e / II 2D Ex t	See table	0589739
46xx	M20 x 1,5	5,0 ... 14,0	Nickel plated brass	II 2G Ex e / II 2D Ex t	-	0589654
46xx	M20 x 1,5	10,0 ... 14,0	Nickel plated brass	II 2G Ex d / II 2D Ex t	-	0588851
46xx	1/2 NPT	7,5 ... 11,9	Nickel plated brass	II 2G Ex d / II 2D Ex t	-	0588925

\*3) The limitation of the temperature range to the mentioned range is due to the self-heating of the solenoid.

For solenoid	Ambient temperatur limitation solenoid 42xx		
	0589735 & 0589736 *4)	0589737	0589739 *4)
422x/427x	T4 & Staub Ex: -35°C +65°C	T4 & Staub Ex: -40°C...+ 62°C	T4 & Staub Ex: -40...+65°C
	T5: -35°C + 55°C	T5: -40°C + 55°C	T5: -40...+55°C



\*4) Tested for the lower level of mechanical risk (4 joule), an additional protection against impacts might be needed.

Connector Form A	Silencer *1)	Exhaust guard *2)
		
0570275	Page 7 C/S2 (1/4 NPT) M/S2 (G1/4)	Page 7 0613422 (G1/4, 1/4 NPT)

\*5) For indoors use

\*6) For outdoors use, opening pressure ~ 0,2 bar

### NAMUR accessories (only G1/4)

Throttle control plate *7)	Flange plate	Yoke	Mounting plate	Quick exhaust module *8)
				
Page 7 4040239	Page 6 0612790 (NAMUR single connection plate) 0612791(NAMUR-rip use in combination with 0612790)	Page 7 0540593 (Pipe mounting use in combination with 0612790)	Page 7 0613453 (90°)	Page 6 4050218

\*7) The throttle control plate 4040239 has a minimum flow rate for safety reason.

\*8) Technical details see catalogue page en 5.4.820.

## Dimensions

### Valves

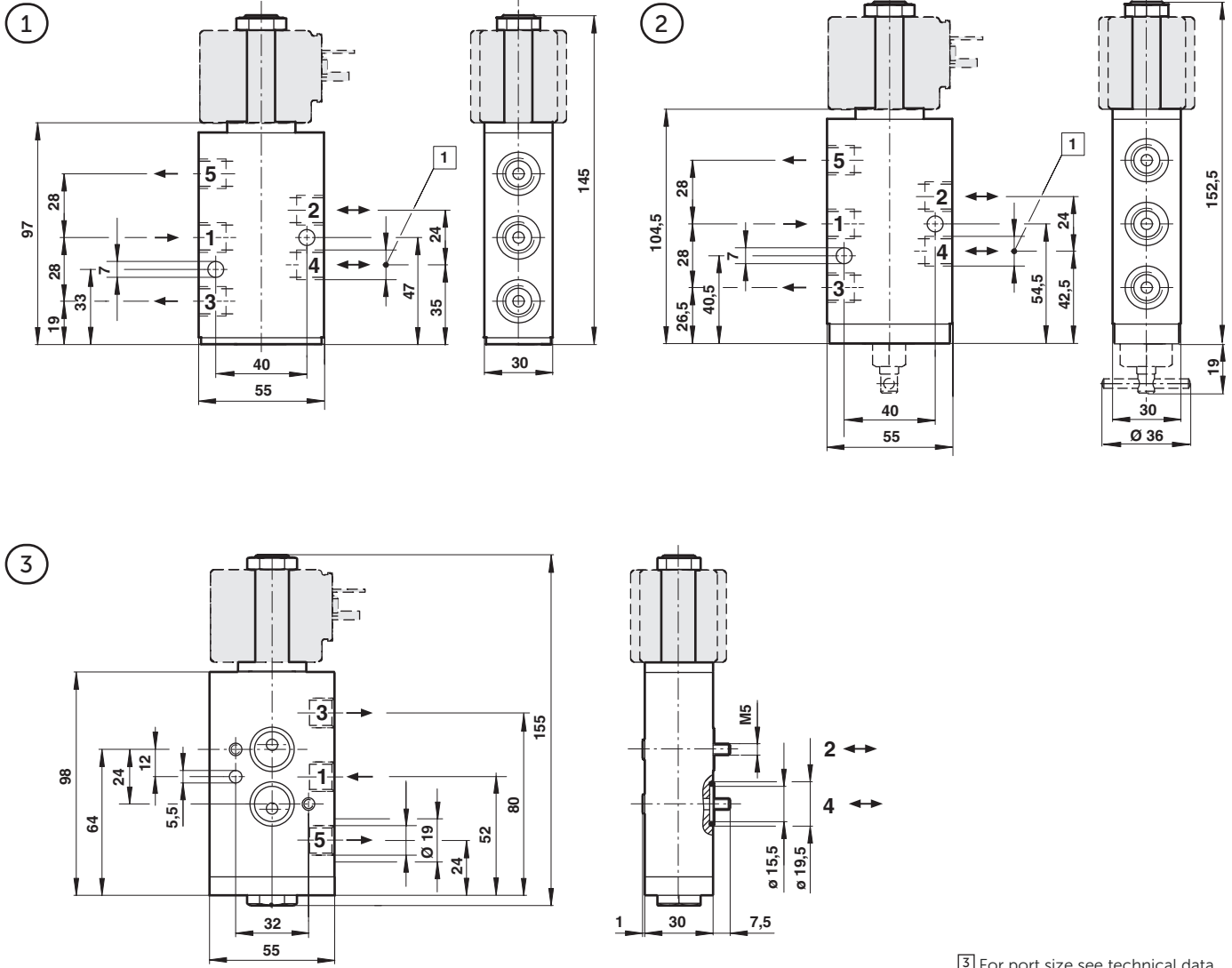

[3] For port size see technical data

## Dimensions

### Solenoids

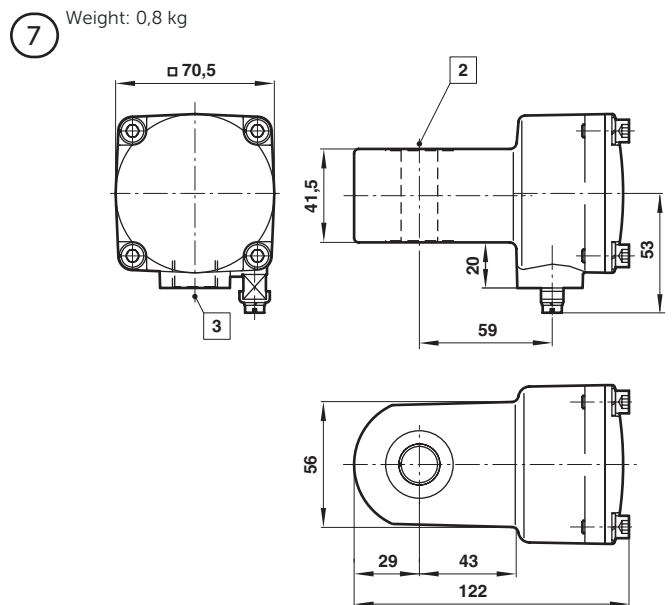
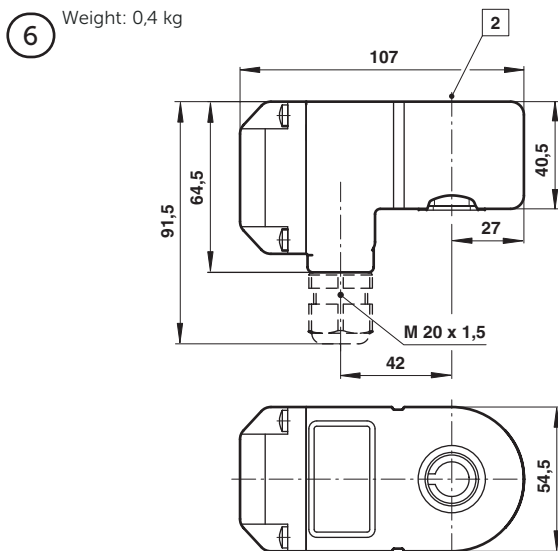
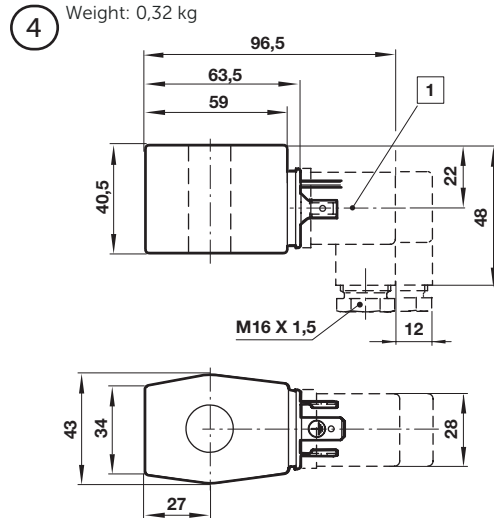
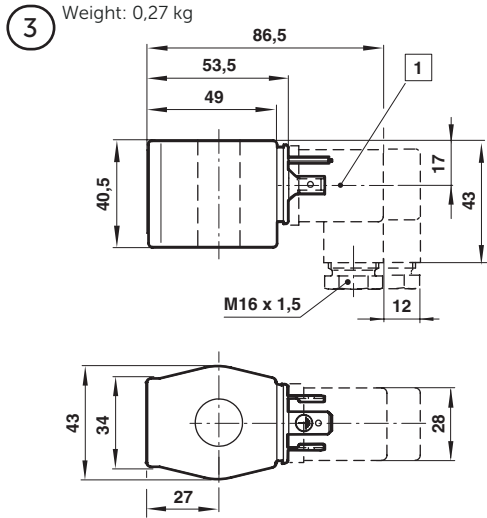

- ① Connector can be indexed by 4 x 90
- ② Ø 16 or 13 (with spacer tube)
- ③ M20 x 1,5 or 1/2 NPT

### Circuit diagrams

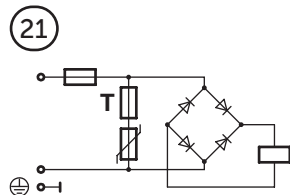
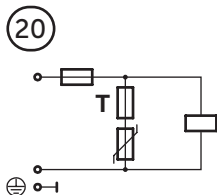
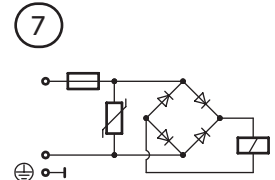
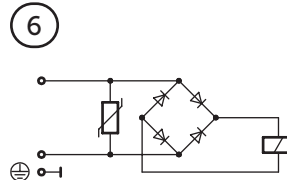
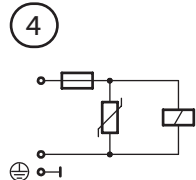
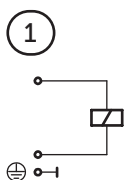

## NAMUR hole pattern (driving side)

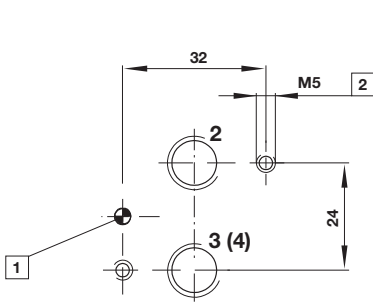

- 2 Port 2 (A)
- 3 Coding stud threaded
- 4 M5 (10 deep)
- 5 Port 3 (R)

NAMUR quick exhaust module for a better kv-value by exhaust see data sheet 5.4.820

NAMUR interlinking plates in redundancy design for »safety exhausting« and »safety ventilating« see data sheet 5.4.830

## Single connection plate Model: 0612790

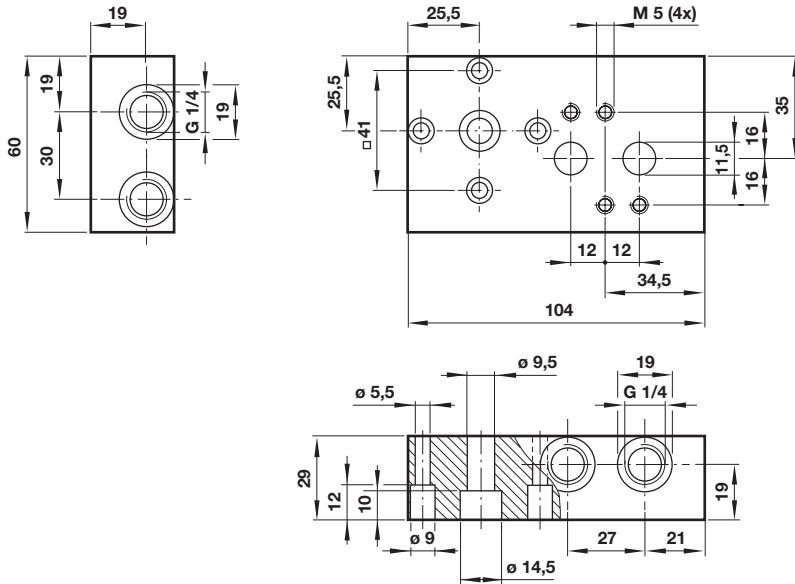

## NAMUR-rip use in combination with 0612790 Model: 0612791

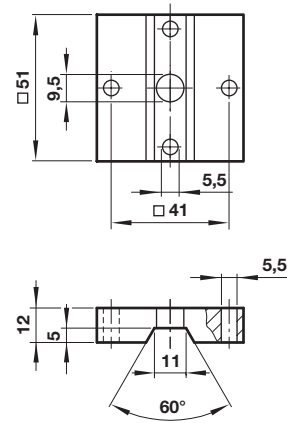

## Quick exhaust module Model: 4050218

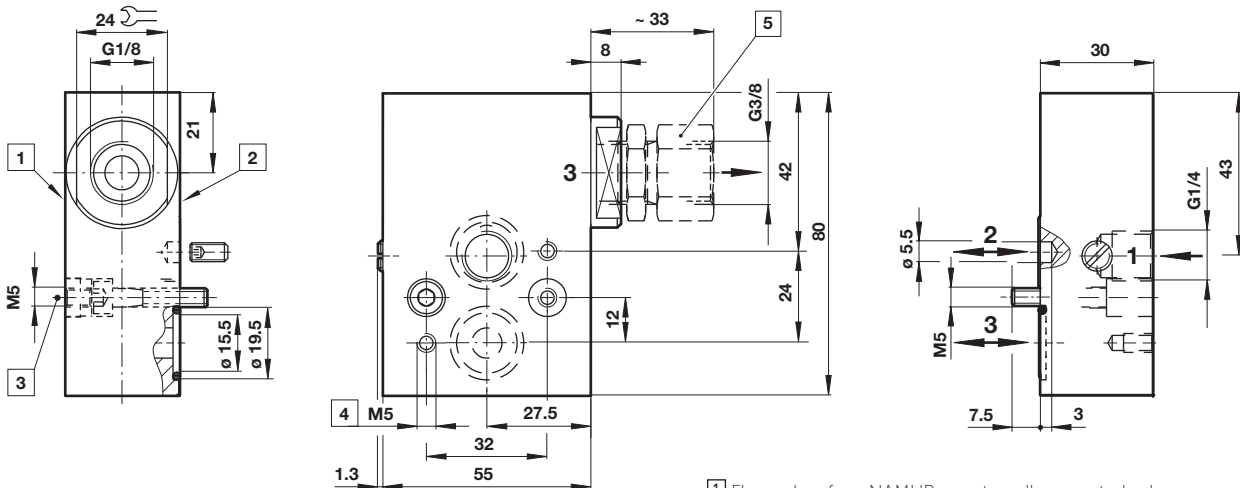

- 1 Flanged surface NAMUR or externally mounted valve
- 2 Flanged surface NAMUR actuator
- 3 Push-in threaded piece after plate mounting (to secure correct position)
- 4 8 mm deep
- 5 Flow regulator retrofittable

**Yoke use in combination with 0612790**  
**Model: 0540593**

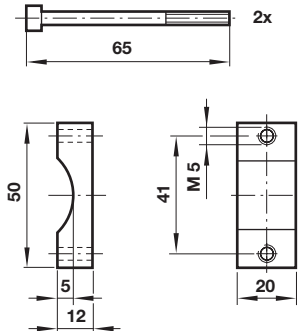

**Throttle control plate**  
**Model: 4040239**

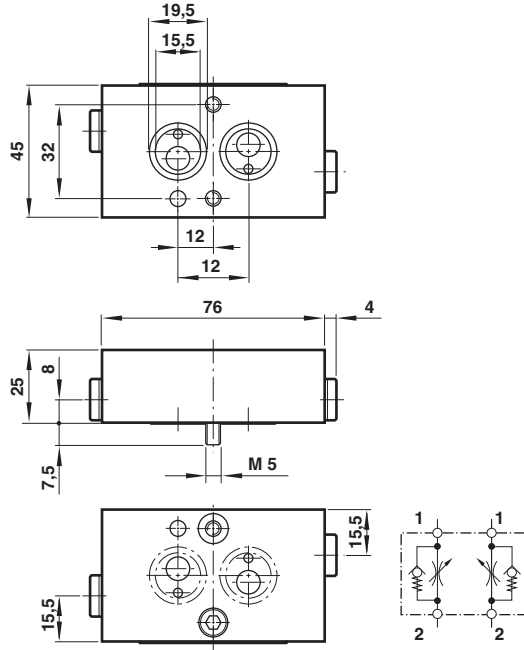

**90° Mounting plate**  
**Model: 0613453**

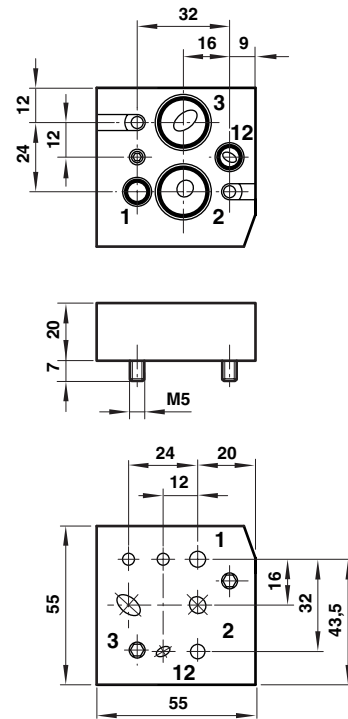

**Silencer**  
**Model: M/S2, C/S2**

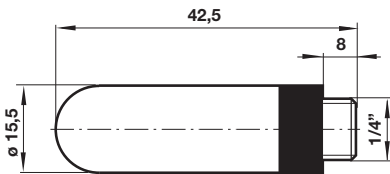

**Exhaust guard**  
**Model: 0613422**

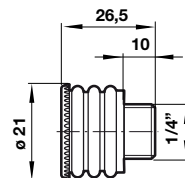

**Cable gland**

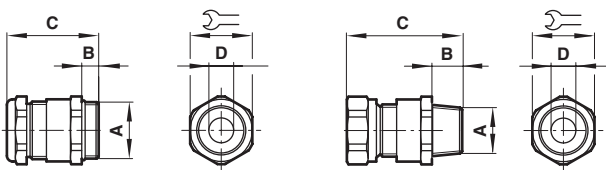

0588925 only

A	B	C	ø D	⚡	Model
M20 x 1,5	10	40	7,0 ... 12,0	24	0589735
M20 x 1,5	10	43	10,0 ... 14,0	27	0589736
M20 x 1,5	10	40	6,0 ... 12,0	24	0589737
M20 x 1,5	10	39,5	5,0 ... 10,0	24	0589739
M20 x 1,5	6,5	35,5	5,0 ... 14,0	24	0589654
M20 x 1,5	12	37	9,0 ... 14,0	30	0588851
1/2 NPT	15	58	7,5 ... 11,9	24	0588925

**Warning**

These products are intended for use in industrial compressed air systems only. Do not use these products where pressures and temperatures can exceed those listed under »**Technical features/ data**«.

Before using these products with fluids other than those specified, for non-industrial applications, life-support systems or other applications not within published specifications, consult Norgren.

Through misuse, age, or malfunction, components used in fluid power systems can fail in various modes.

The system designer is warned to consider the failure modes of all component parts used in fluid power systems and to provide adequate safeguards to prevent personal injury or damage to equipment in the event of such failure.

System designers must provide a warning to end users in the system instructional manual if protection against a failure mode cannot be adequately provided.

System designers and end users are cautioned to review specific warnings found in instruction sheets packed and shipped with these products.